

# **SOLAR ENERGY RESEARCH ENCLAVE**

submitted to

**Indian Institute of Technology Kanpur**



**R.S. Anand (EE)**

**M.K. Das (ME)**

**S.S.K. Iyer (EE)**

**S. K. Mishra (EE)**

**P.S. Sensarma (EE)**

**A. Singh (IME)**

**Co-coordinator: R.G. Pala (ChE)**

**Coordinator: Monica Katiyar (MME)**

August 2009

## Acknowledgements



With support from students of G3 group – IITK

Anand Vardhan Mishra (ME-Y7047)

Rahul Verma (CHE-Y7343)

Shashank Tripathi (CHE-Y8473)

## Table of Contents

<b>1. SUMMARY .....</b>	<b>4</b>
1.1 PROJECT SUMMARY.....	4
1.2 PROJECT TEAM.....	5
1.3 BUDGET.....	5
1.4 PROJECT DATA .....	6
1.4.1. Technology .....	6
1.4.2. Site location.....	6
1.4.3. Plant design and scheme .....	6
1.4.4. Environmental aspects.....	7
<b>2. INTRODUCTION.....</b>	<b>8</b>
2.1. OBJECTIVE OF PROJECT .....	9
<b>3. SOLAR PV POWER GENERATION TECHNOLOGY .....</b>	<b>9</b>
3.1 TYPE OF SOLAR CELLS AVAILABLE.....	10
3.2. TECHNOLOGY ELEMENTS IN CURRENT PLANT DESIGN .....	11
<b>4. ENERGY STORAGE TECHNOLOGIES .....</b>	<b>13</b>
4.1 AN OVERVIEW .....	13
4.2 STORAGE TECHNOLOGIES ELEMENTS IN CURRENT PLANT DESIGN .....	15
<b>5. POWER ELECTRONICS .....</b>	<b>15</b>
5.1 GRID-INTERACTIVE OR STANDALONE SOLAR PV SYSTEMS: .....	15
5.2. ELECTRICAL EQUIPMENT AND SYSTEM.....	15
<b>6 SITE SELECTION .....</b>	<b>17</b>
6.1. GEOGRAPHICAL LOCATION .....	17
6.2. SITE PREPARATION .....	17
<b>7. FINANCIAL ANALYSIS OF IIT KANPUR SOLAR POWER PLANT .....</b>	<b>21</b>
<b>8. ENVIRONMENTAL PROTECTION PLAN.....</b>	<b>22</b>
<b>9. PROJECT EXECUTION.....</b>	<b>22</b>
9.1. PROJECT EXECUTION STRATEGY.....	22
9.2. PROJECT SCHEDULE.....	23
<b>10. TECHNOLOGY DEVELOPMENT .....</b>	<b>23</b>
<b>ANNEXURE A. CV OF CORE MEMBERS OF SERE TEAM.....</b>	<b>25</b>
<b>ANNEXURE B. SOLAR CYCLE ANALYSIS.....</b>	<b>35</b>
<b>ANNEXURE C. RESEARCH PROJECTS .....</b>	<b>38</b>
DEVELOPMENT OF HIGH EFFICIENCY SILICON AND POLYMER SOLAR CELLS .....	38
SOLID STATE REDUCTION ROUTE FOR THE PREPARATION OF LOW COST ELECTRONIC GRADE Si IN SOLAR CELL APPLICATION.....	43
ENERGY STORAGE TECHNOLOGIES.....	46
SOLAR ENERGY: ECONOMICS AND PROJECT IMPLEMENTATION.....	50

## 1. SUMMARY

### *1.1 Project summary*

For close to three decades, tapping the energy from the sun has always had great potential but large scale utilization has faced many bottlenecks. Amongst the many bottle necks are cost of technology, energy storage, distribution of solar power and daily/seasonal variability of solar resource. In the present initiative, we address these challenges under three broad research themes of solar energy capture, distribution and storage. We propose to initiate a solar energy research enclave with the following objectives:

- a) **We will establish a technology demonstrator –1 MW (peak) solar power station in two phases. It will supplement electricity requirement of IITK campus during day time (8 hrs) and thus help in reducing dependence on grid power. This will also generate useful data for future implementation of such projects in the region.**
- b) **Modules in the solar power station will be used for research and as test platforms for large scale solar energy technologies.**
- c) **We will initiate new and augment the existing programs for long term research & development in solar power generation, storage, distribution, management and policy making in the institute.**
- d) **This initiative will provide practical input for graduate and undergraduate teaching programs. In addition, it will provide training and human resource development in the area of renewable energy**
- e) **Finally, it will increase the awareness of green technologies amongst the public.**

We feel that establishment of solar power station will augment the energy supply of the institute and provide us with an in-depth evaluation of many existing solar technologies. The solar power station will be built in a modular fashion such that some of the individual modules can be utilized for demonstration and testing of technologies developed in house. The research and technology activities centered on three main areas, namely, material and device research in photovoltaic technologies, system integration and power distribution and energy storage technologies is highly inter disciplinary requiring analysis and synthesis across departments. The goal oriented interdisciplinary research will lead to development of technology that can be integrated into the solar power station that is being proposed. The present document outlines the design of the solar power station and some of the research projects that are emphasized in the first phase of the long term initiative.

## 1.2 Project Team

Interdisciplinary team of following core members (Brief CV attached in Appendix A):

Malay K. Das (ME)  
Raj Ganesh Pala (ChE)  
Santanu K. Mishra (EE)  
Raghubir S. Anand (EE)  
Partha S. Sensarma (EE)  
Anoop Singh (IME)  
S. Sundar Kumar Iyer (EE)  
Monica Katiyar (MME)

Extended Team consisting of Professor Shyama P. Das (EE), Sameer Khandekar (ME), Kantesh Balani (MME), Krishanu Biswas (MME), Deepak Kunzru (ChE), Nitin Kaistha (ChE), Goutam Deo (ChE), Y. N. Mohapatra (Phy), Kallol Mandal (MME).

## 1.3 Budget

### Ist Phase:

Estimated cost of a 500kWp solar sub-station and research initiation (in crores):

	Ist Year	IInd year	IIIrd year
<b>PV- panels (Assuming a mix of technologies to be used and average cost Rs.200/kW<sub>p</sub>)</b>	<b>10.5</b>		
<b>Fuel Cells/Batteries</b>	<b>3.5</b>	<b>0.5</b>	<b>0.5</b>
<b>Power Electronics and monitoring equipment</b>	<b>4</b>		
<b>Operational cost, maintenance and security</b>		<b>0.5</b>	<b>0.5</b>
<b>Research initiation for low-cost Si material, high efficiency PV, fuel cells and power electronics</b>	<b>2</b>	<b>1</b>	<b>1</b>
<b>Total</b>	<b>20</b>	<b>2</b>	<b>2</b>

\*Budget does not include the cost of site preparation and required construction.

### IInd Phase

- Expansion of solar plant capacity to 1 MW with inputs from Ist phase
- Testing of developed technologies to improve efficiency and lower the cost of the systems
- Setting up facilities for basic research and technology development

## **1.4 Project Data**

### **1.4.1. Technology**

There are several PV technologies available in the market and our aim is to maximize the number of technologies installed at SERE. We are proposing to use multicrystalline Si solar cells, amorphous silicon solar cells, and 2D-concentrators using micromorph Ge/GaAs/GaInP Solar Cell Technology.

Solar plant will use state-of-the-art-technologies for power electronics. The plant will have ten 50 kWp modules and a 5 kWp module for innovative storage research. The following power electronics researches are planned.

- Control schemes for paralleling of dc-dc converters & MPPT
- Control schemes for paralleling of dc-ac inverters & grid synchronization
- Remote Phasor Measurement

Power will be supplied directly to IITK sub-station with partial storage using batteries to ensure the solar plant power needs are met internally (500 kWhr). New technology to be implemented in a test module of 5kWp is Fuel cell (Fuel cell- floor area: 1.0m<sup>2</sup>, height: 1.0m, weight: 20kg. Hydrogen generator- floor area: 2.0m<sup>2</sup>, height: 2.0m, weight: 60kg)

- Fuel Cells: low-temperature polymer electrolyte fuel cells (5kW)
- Reforming reactors: methanol reformer, water-splitting reactor

### **1.4.2. Site location**

For the solar plant, an area of 5-6 acres (20000 -24000 m<sup>2</sup>) is estimated to install photovoltaic panels for 500kWp including service, maintenance, instrumentation, data collection, storage, panel preparation, control room, storage, research test-beds), and security.

A possible location, within IITK for SERE is the land between the Shivli road and lower Ganga canal. Since high tension lines pass through this area, this land cannot be used for other activities at present. The remaining part can be developed as an orchard to ensure dust-free environment around the PV-panels. This can also be used for expansion of the energy distribution capacity in future.

### **1.4.3. Plant design and scheme**

There are two components to the solar power plant:

- 500 KW (peak) solar power plant using PV technologies to supply to sub-station-II of IIT Kanpur
- Plant will be designed in modules for testing of solid oxide fuel cells, photovoltaic technologies, and power electronics schemes

#### **1.4.4. Environmental aspects**

Main environmental concern will be to ensure proper mechanism of battery or PV panel disposal or recycling.

## 2. INTRODUCTION

With the increasing demand of energy via *greener* methods and the gradual depletion of fossil fuels, solar energy conversion has regained the spotlight of the global energy activities. Our planet receives 160,000TW solar energy, while the present global energy demand is about 16TW. While the solar resource is virtually unlimited, conversion of solar energy to readily usable form is too expensive to be commercially successful at present. Furthermore, reliable solar technology has to be complemented by energy storage system to accommodate the daily and seasonal variations in the solar radiation. From this perspective, many countries have formulated their long term solar energy utilization roadmap. For instance, the Japanese roadmap includes development of solar photovoltaic at competitive price by 2030. Large demonstrative projects (~MW) are underway in USA, Australia, and in several European countries. These projects serve multiple purposes.

- First, the projects tend to reduce the overall cost of the energy technology as large scale utilization of a particular technology, in general, tends to reduce the cost of that technology. This has also encouraged the entrepreneurs to invest in solar energy technologies.
- Second, the projects are serving as test platforms for large scale solar energy utilization technologies.
- Third, these projects are engaging the academic institutions in long-term solar energy research, development, and pedagogical activities.
- Fourth, these projects have increased the awareness of green technologies amongst the public

All such projects and roadmaps are, however, only a part of the country-specific long-term energy vision, with solar energy aiming to supplement conventional energy technologies. None of these initiatives, at this stage, claim to replace the existing fossil-fuel based systems immediately.

Being a developing country with a huge burden of fuel import, the need of solar energy research and development in India cannot be over-emphasized. The geographical location of India is also quite favorable for solar energy implementation. However, a densely-populated country like India, with a fragmented electricity market, poses endless challenges to the scientists and entrepreneurs. The nature of Indian electricity market is quite unique, and cannot be compared directly with other countries. Unlike USA or Japan, India has *numerous villages and islands unconnected from the main grid*, spatial and seasonal variation in agricultural demand, and cottage- to large-scale industrial sectors. Our country, therefore, requires solar energy development at different scales such as, small (~W) to large (~MW), grid-connected to islanded, supplemented with some energy-storage to no-storage capabilities. Also important is the hybridization of solar energy with other renewable sources. Considering this socio-economic scenario, the present state of solar energy technology in India stands far from being adequate, but



several initiatives are being planned. On 30<sup>th</sup> June 2008 the Prime minister of India, Dr. Manmohan Singh, announced the National Plan for Climate Change.<sup>1</sup> This includes a National Solar Mission to “significantly increase the share of solar energy in the total energy resources while recognizing the need to expand the scope of other renewable and non-fossil options such as nuclear energy, wind energy, and biomass”. The departments of Science and Technology (DST) and the ministry for New and Renewable Energy (MNRE) have taken initiatives to promote formation of networks of premier research institutes to work on solar power generation related projects. One such scheme is DST’s Pan-IIT Solar Energy Initiative (PSI) with a goal of delivering a 1MW solar based islanded energy grid in 5yrs. A multi-disciplinary team from four departments of IIT Kanpur has been participating in this initiative.

To further strengthen the contribution to the National Solar Mission and the PSI, it is felt that a broader inter disciplinary group can be formed at the institute level aiming to develop short and long term technology in the area of power electronics component and system design, solar energy materials, supplementary energy storage and conversion devices. An establishment of Solar Energy Research Enclave will catalyze the accomplishing of this goal of national importance, and this is the genesis of this proposal for Solar Energy Research Enclave (SERE).

### ***2.1. Objective of project***

The primary objective of the solar energy research enclave will be two-fold a) Establishment of a solar power station that can supply 1MW<sup>3</sup> power b) Outline the research areas that will be explored for sustainable solar energy generation, storage and distribution.

The solar power station will be built in modular fashion such that different technologies can be utilized/tested for generating power. The modules will be designed not only as a demonstrator of existing technologies but also to explore cutting edge research technologies that have potential for economic viability.

The over view of the solar power station will be presented in Section 3. The various research projects that will be explored under the present initiative is presented in Section 4.

## **3. Solar PV Power Generation Technology**

**Photovoltaics (PV)** is the field of technology and research related to the application of solar cells for energy by converting sun energy (sunlight, including sun ultra violet radiation) directly into electricity. Due to the growing demand for clean sources of energy, the manufacture of solar cells and photovoltaic arrays has expanded dramatically in recent years. Photovoltaic production has been doubling every 2 years, increasing by an average of 48% each year since 2002, making it the world’s fastest-growing energy technology. At the end of 2008, the cumulative global PV installations reached

---

<sup>1</sup> National Action Plan on Climate Change, Released on 30<sup>th</sup> June 2008 by Govt. of India

15,200 Megawatts. Roughly 90% of this generating capacity consists of grid tied electrical systems. Such installations may be ground-mounted (and sometimes integrated with farming and grazing) or built into the roof or walls of a building, known as Building Integrated Photovoltaic or BIPV for short.

Net metering and financial incentives, such as preferential feed-in tariffs for solar-generated electricity; have supported solar PV installations in many countries including Australia, Germany, Israel, Japan, and the United States.<sup>2</sup>

### ***3.1 Type of solar cells available***

The PV cells are manufactured by hundreds of manufacturers worldwide and there are several different technologies available. There are three main type of commercially available PV cells viz.

1. Mono crystalline silicon PV
2. Polycrystalline silicon PV
3. Thin film amorphous silicon PV

At present the first two categories dominate world markets constituting 93% of it the last one accounts for 4.2% of the market. There are other type of solar cells but are less in use viz. concentrated photovoltaic, hybrid solar cells, multi junction solar cells etc. However, their production is lower because of less usage till now, and thus they are truly not commercial.

The **silicon based technologies**, crystalline(c)-Silicon, multi-crystalline(mc)-Silicon, amorphous (a)-silicon are the dominant technologies at 24%, 19% and 12% efficiencies at cell levels [1,2,3]. The efficiencies at module levele are 5-6 % lower due to variety of reasons. Most of the Indian companies are producing at 15-17% efficiencies at cell levels and at about 12-13% at module levels. There is scope of improvement in different technologies. We like to put up state of the art efficient modules.

A **Thin-Film Solar Cell** (TFSC), also called a **Thin-Film Photovoltaic Cell** (TFPV), is a solar cell that is made by depositing one or more thin layers (thin film) of photovoltaic material on a substrate. The thickness range of such a layer is wide and varies from a few nanometers to tens of micrometers.

Many different photovoltaic materials are deposited with various deposition methods on a variety of substrates. Thin Film Solar Cells are usually categorized according to the photovoltaic material used. The following catgories exist:

- **Cadmium Telluride (CdTe)**
- **Copper indium gallium selenide (CIS or CIGS)**

---

<sup>2</sup> Wikipedia

- **Dye-sensitized solar cell (DSC)**
- **Organic solar cell**
- **Amorphous silicon (a-Si)**

On an average the efficiency of thin film cells are 6-12% furthermore the thin-film PV market is showing a spectacular annual growth rate of 126% in 2007. These thin film solar cells will be suitable for window and facades in Building Integrated PV (BIPV) technologies.

**High efficiency solar cells with concentrators:** Highest efficiency solar cells have been demonstrated using micromorph triple junction Ge/GaAs/GaInAsP materials. Technology is quite intricate and cost of triple junction solar is quite high. Hence, these cells are primarily used for satellite applications. For terrestrial applications, these cells are used in high concentration mode to reduce usage of costlier cells. Using optical reflectors, light is concentrated from 200-500 times on 1 cm<sup>2</sup> active area. The Sun is tracked daylong in two dimensions to keep the sun-spot on device area. Only few companies have mastered the cell and tracker technologies. There is need to know better and perfect the cell and tracker technologies. A six modules panel of 1.2KWp power with 2D tracker is installed at IITK. A photograph 12 panel module is shown in Fig.1. We like to install 100 kWp high efficiency Solar Concentrators at the research enclave.



Fig.1 High Efficiency Solar Concentrator

### ***3.2. Technology elements in current plant design***

There are lot of developments taking place in different front of PV R&D, manufacturing and installation. Prices vary vastly from company to company, country to country and from one technology to another depending of efficiency of modules and services provided. Presently, prices as defined per Watt Peak (W<sub>P</sub>) are declining. A trend of average price is shown in Fig.2.<sup>3</sup>

<sup>3</sup> <http://www.solarbuzz.com/Moduleprices.htm>

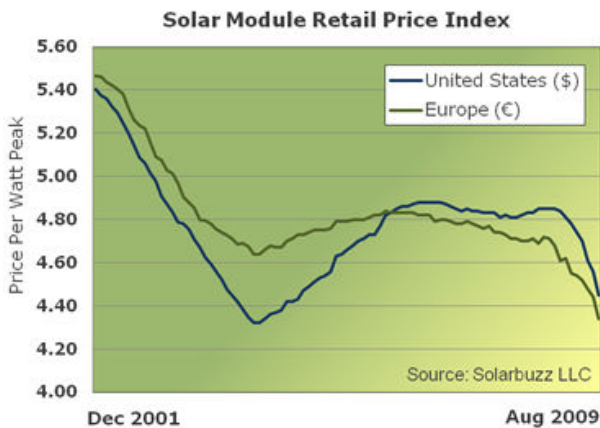

Fig. 2 Graph of Solar Module Price

According to Survey report of Solar Buzz, as of August 2009, there are currently 475 solar module prices below \$4.75 per watt (€3.32 per watt) or 34.3% of the total survey. The lowest retail price for a multi-crystalline silicon solar module is \$2.48 per watt (€1.74 per watt) from a US retailer. The lowest retail price for a monocrystalline silicon module is \$2.80 per watt (€1.96 per watt), from a US retailer. At recently held 3<sup>rd</sup> Renewable Energy India 2009 Expo held at Pragati Maidan from 10-12 Aug 2009, modules of 13% efficiency are available at Rs.120-150/Wp in bulk.

Note, however, that "not all models are equal." In other words, brand, technical attributes and certifications do matter.

The lowest thin film module price is at \$1.76 per watt (€1.23 per watt) from an Asian-based retailer. As a general rule, it is typical to expect thin film modules to be at a price discount to crystalline silicon (for like module powers). This thin film price is represented by a 130 watt module.

Keeping the above in view the prices of PV modules in international market and also the discussion, the PV group at IITK had with representative of major PV manufacturer like Tata BP Solar and Moser Baer Photovoltaic Ltd, 500 KWp PV modules having a mix of different state of the art technologies can be installed.

## 4. Energy Storage Technologies

### 4.1 An overview

Traditionally, batteries are the storage technology that is considered for back up power. In a battery, the electrical energy is stored using a chemical redox couple whose free energy is increased while the battery is being charged, and the decrease in free energy is used for supplying current during discharge. The chemical redox couples, which is the fuel for the battery, is usually in the solid form and are enclosed along with an ion conducting electrolyte. The battery life is determined by the number of charge-discharge cycles and the entire unit (redox couple/electrolyte) needs to be replaced after certain number of cycles. In contrast to this approach, it is possible to have electrical storage devices in which the chemical redox couple (i.e. the fuel) are supplied continuously and such devices are called fuel cells (fig 1).

Two central factors that determine the quality of an energy storage device are the power density and the energy density. While these two factors are comparable for batteries and fuel cells (fig \*), the periodic replacement of the storage unit is not necessary for a fuel cell. Due to this and other factors, there has been a resurgence of interests in fuel cell technology as a potential replacement for batteries, especially when the back up requirement is quite large. Some solar PV farms already have fuel cell technology as the energy back up device.

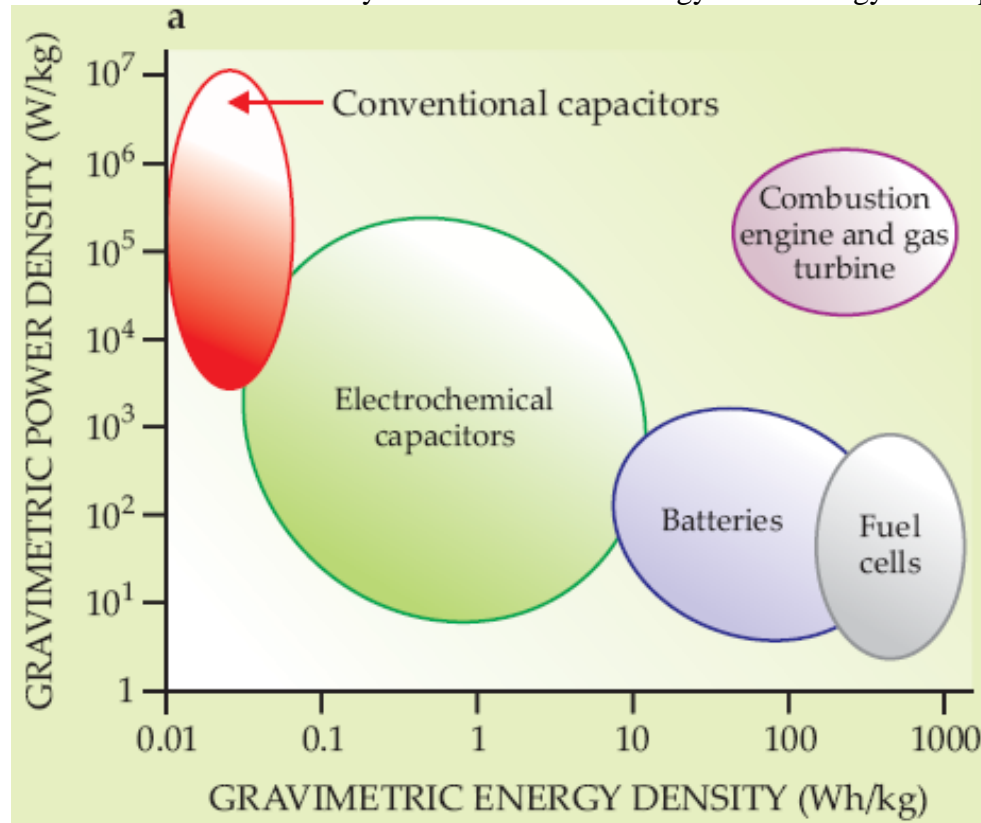

Figure 3. Comparison of different storage technology

Depending on the nature of the fuel and the nature of the ion conducting electrolyte, a variety of fuel cell configuration is possible (Fig. 2.)

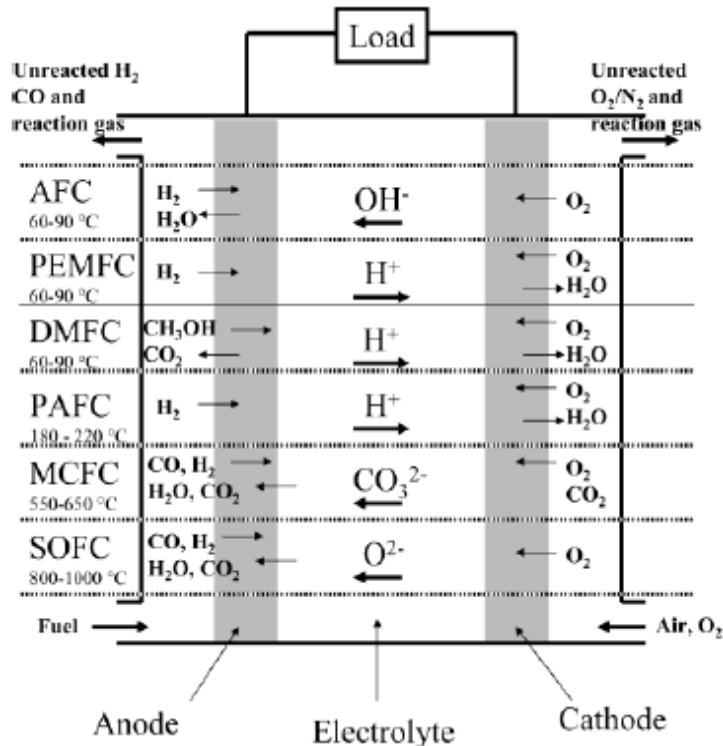

Figure 4. Comparison of different fuel cell technologies

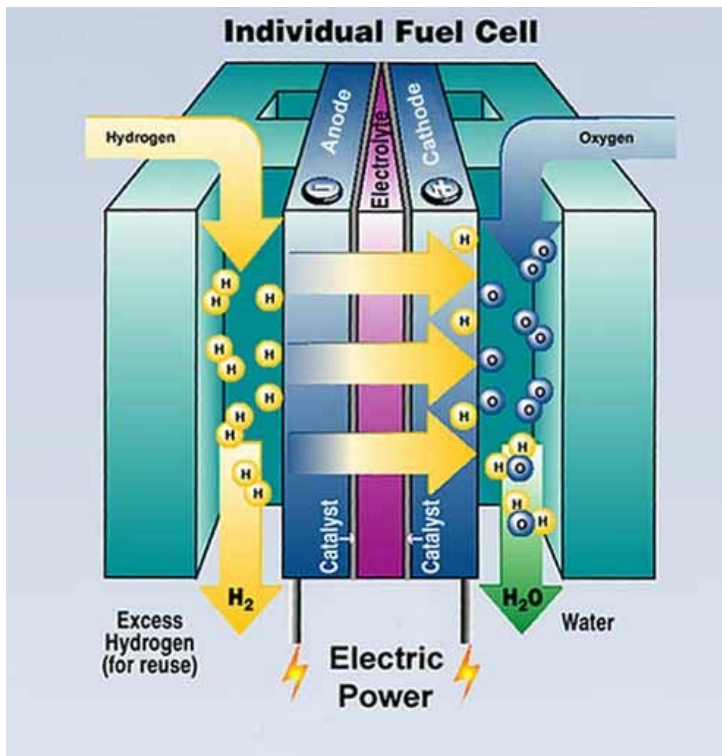

Figure 5. Working principle of PEMFC

## ***4.2 Storage technologies elements in current plant design***

We plan to put a 5kW polymer electrolyte membrane fuel cell (PEMFC) system (Fig. 3.) in the technology demonstration station. A hydrogen generation unit will also be installed to support the fuel cell system. The choice of PEMFC stems from the fact that the PEMFC technology is now reasonably well developed. On the other hand, development of high-temperature fuel cell technologies, such as the solid oxide fuel cells (SOFC), requires considerable basic research. Unlike PEMFCs, which require pure hydrogen, SOFC systems may utilize multiple fuels and can be hybridized with the existing heat engine technologies. SOFC systems are, therefore, quite attractive for stationary power generation. Our research plan focuses on the development of SOFC systems. The objective is to develop a 1kW SOFC system. Detail research plan is described elsewhere.

## **5. POWER ELECTRONICS**

### ***5.1 Grid-interactive or standalone Solar PV systems:***

A team of SERE members visited a 100 kWp standalone solar power plant in Tangste, Ladakh and a 100 kWp grid-interactive solar power plant in Basti. One of the main messages merging out of this visit is that local conditions significantly influence the choice of technology, storage and the decision to be grid-interactive. It is found that for the success of a grid-interactive plant, the power availability in local grid is required to harness the power generated from the plant. Due to absence of storage, the power generated should be consumed in the local grid itself.

Such a design also has implication of on the potential to supply electricity to local villages / institutions. To achieve this, such potential beneficiaries should either be connected to IITK sub-system or be powered at least during the day when solar power is generated.<sup>4</sup>

On the other hand, a standalone plant requires a lot of energy storage. Being in the IITK campus, we are planning this solar power plant as supplementary energy source for the IITK's internal distribution during the day time (8 hrs) – like a Diesel Generator.

### ***5.2. Electrical equipment and system***

The overall plan for the power plant is shown in Figure 3. The system is divided into 10 sections of 50 kW each. In the following explanation each section will be referred to as a “string.” Each string consists of a 50 kW solar panel, two 25 kW charge controller connected in parallel, and a pair of parallel connected inverters. The requirement of the parallel modules for the charge controller and inverter makes the system efficient and convenient for research usage.

---

<sup>4</sup> **Solution:** One of the solution could be to identify public institutions (like schools, panchayat, PHC, Anganwadi etc.) in the neighbourhood for providing electricity from the plant. Since these institutions normally function during the day, the generated solar power can be appropriately utilized. This would require some investment to provide electricity cable connection from the plant. This solution satisfies the ‘public benefit’ criteria and avoids ‘private rents’

The charge controller is required to have maximum power point tracking (MPPT) algorithm for better power utilization. A tubular type Li-ion battery bank is connected between the charge controller and the inverter. The charge controller and inverter only allow unidirectional power flow. That implies the battery can only be charged from the solar panels and not the grid.

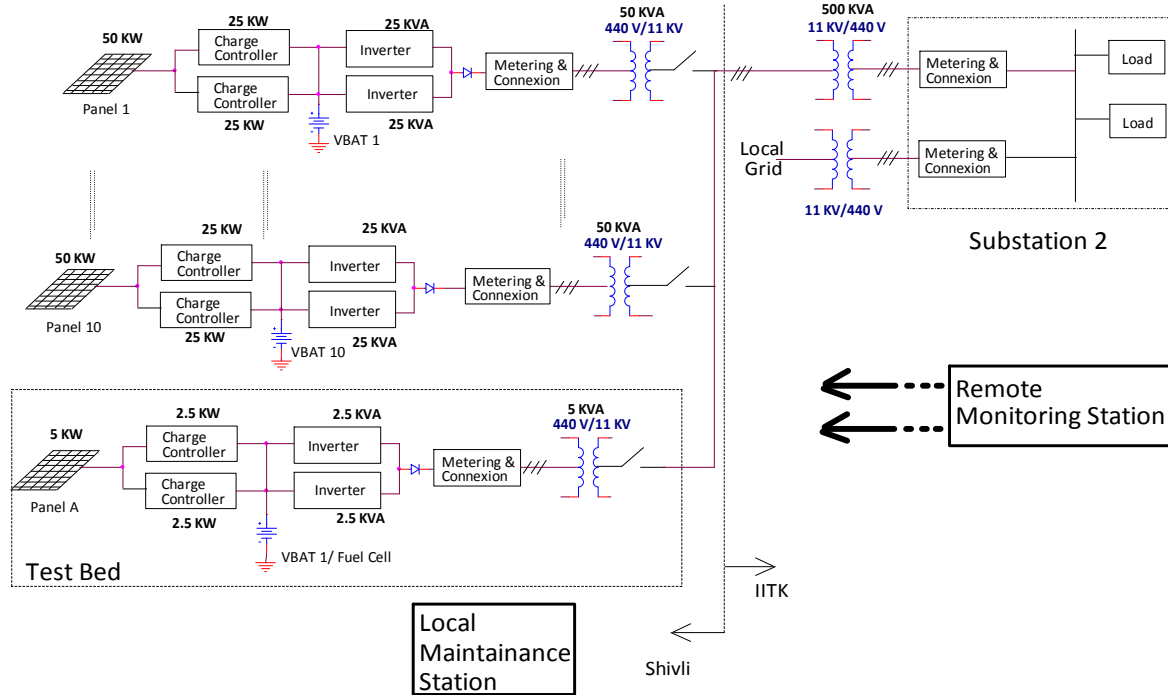

Figure 6. Proposed overall plan for the power plant.

Each string is connected to a dedicated utility transformer through suitable metering and connection. The utility transformer converts the inverter output, which is at a 440 V level to 11 kV. This is required to limit the distribution loss from Shivli site to IITK substation, which is about 3 km away. At the IITK substation the voltage is stepped back down to 440 V and supplied to the load. Table 2 provides the suggested electrical ratings of each power electronics block in a string. The size (expressed as A-hr) of the battery is purely based on the amount of back-up needed during the down time of the solar plant.

This proposed architecture provides the following advantages.

- Different suppliers can be selected for each string without affecting the performance of the overall system.
- Maintenance of one string doesn't significantly affect the system. This is important from an interdisciplinary research point of view as there will be a constant need to disconnect strings out of the grid to experiment on various research modules.
- Individual string power output can be monitored and efficient processing units can be singled out. This makes a good requirement for the advancement of the technology.



- The need for power electronics processors (charge controllers/ inverters) on each string will be of a lower rating, which makes it convenient for prototype design to facilitate research.

Apart from the power processing unit, the team proposes the inclusion of a state-of-the-art remote monitoring station at IITK. This will help monitor the voltages at each node and power flow from each solar panel to IITK substation. A local maintenance station is also proposed with dedicated technician at the site 24/7 to take care of any maintenance need. This maintenance station can be housed inside the power processing shelter.

**Table 1: Rating of power electronics components per string**

<b>Blocks</b>	<b>Suggested Voltage Rating</b>	<b>Required Power Rating</b>
Charge controller	600 VDC	50 kW
Battery	300 VDC	NA
Inverter	440 VAC	50 kVA
Utility Transformers	440 V/11 kV	50 kVA
Substation Transformers	11 kV/ 440 V	500 kVA

## 6 Site Selection

### 6.1. Geographical location

Kanpur is situated at Latitude 26.4 and Longitude 80.4, based on this solat cycle analysis was generated from NASA site.<sup>5</sup> (See Appendix B for detailed data). Monthly Averaged Insolation Incident<sup>6</sup> on a horizontal surface ranges between 3.6-6.32 kWh/m<sup>2</sup>/day. Annual Averaged Insolation Clearness Index ranges from 0.46 -0.62.<sup>7</sup> These climatic conditions are better than many other locations of large PV based solar plants in the world.

### 6.2. Site Preparation

The space required for putting up PV modules for generation of 500KW<sub>P</sub> electric power, depends on the efficiency of solar modules. An estimate of it is given below:

---

<sup>5</sup> Nasa website

<sup>6</sup> “The monthly average amount of the total solar radiation incident on a horizontal surface at the surface of the earth for a given month, averaged for that month over the 22-year period (Jul 1983-Jun 2005). Each monthly averaged value is evaluated as the numerical average of 3-hourly values for the given month”

<sup>7</sup> Clearness Index: “The monthly average amount of the total solar radiation incident on a horizontal surface at the surface of the earth divided by the monthly average incoming top-of-atmosphere insolation for a given month, averaged over the 22-year period”

**Table 2. Power (kWs) Obtained from Different Technology PV Modules for 1000 m<sup>2</sup> Area**

Comparable systems covering 1000 m <sup>2</sup>			
Technology	Thin Film	Conventional Silicon	State of the Art - High Efficiency
Watts / Panel	65	165	305
Efficiency	9.0%	12.0%	18.7%
kWs	90	120	187

Source: <http://us.sunpowercorp.com/utility/products-services/products/index.php>

As shown in Table 3 above, high efficiency modules will generate double the power of thin film modules. Area required will be half to that of low efficiency modules. Cost of structure, cabling, labor etc will also be reduced to half. Keeping in view the area required for panels and also servicing, 20 m<sup>2</sup> area will be required for generating per kWp power. Hence, a total area of 10000 m<sup>2</sup> will be required for putting up 500 kWp PV Power Station. Another area of 2500 m<sup>2</sup> will be required for servicing, batteries/storage, laboratories for PVs, Fuel Cells, Power Electronics etc.

A land area between lower ganga canal and Shivli Road has been proposed for setting up the Solar Energy Research Enclave (SERE). In this land area, four high tension lines of 400 KV, 320KV, 132 KV and 440Volts are passing through. A view of this is shown in Fig. 4.



Fig.7 A View of the proposed land at Shivli Village

It is quite hazardous to put up any structure directly under these high tension lines. As informed by Mr Sanjay Srivastava, Director (Generation), UPERC, following clearances are mandatory for different high tension lines.

Table 3 Mandatory Clearance from High Tension Wires

Sr No.	Voltage	Clearance in Meters
1.	33KV	5.1
2.	66KV	5.49
3.	132KV	6.1
4.	220KV	7.015
5.	400KV	8.84

Keeping the above requirement in view, a survey of minimum height at maximum sag was carried out. The distances are given below.

Table 4 Measured Clearance from High Tension Wires at maximum sag

Sr No.	Voltage	Clearance in Meters
1.	132KV	8.47
2.	220KV	9.90
3.	400KV	9.74

The height of normal solar panels from ground is about 2 meters and that of solar concentrator is 2.5-3 meters. Hence, it is not desirable to put any PV panel under these lines. On exploring further the land at Shivli, two piece of lands on south-east and on west sides which are sufficiently away from high tension wires, can be utilized for the purpose. The piece of land on south-east is 50x50 meters in triangular in shape. A multistory building of required area for test beds, labs etc can be constructed at this site. An artistic view of the concept building is given in Fig.5. We plan to put up about 25-50 kWp Building Integrated PV (BIPV) on roof, windows and front glass facades. The PV tiles and PV with partial light and partial solar cells integrated on same glass sheets are available.



Fig. 8. An artistic View of PV Research Labs and Test Beds at Shivli

As we cannot put anything under the high tension lines, a strip of land of  $25 \times 500 = 12500\text{m}^2$  can be made available on western side besides the lower Ganga canal. During the meeting with Mr. Mr. Rajesh Awasthi, Chairman, UPERC held on 20 July 09, it was clarified that the 440V lines can easily be displaced out of the Shivli land area. A request to local Electricity authorities has to be made for this. A view of this is shown in Figure 6, 7, and 8. We plan to put there the state of the art high efficiency flat solar PV panels, 2-D concentrator, 1D Tracker and thin film panel PV modules in this area. Different technologies having its unique features in terms of its cell structure, efficiency, mechanical and electrical layouts. Technology of tracking in 1D and 2D is intricate and requires knowledge of earth movement during different time of the year and also tracking and its automation techniques. The knowledge, analysis and design innovation will be a good research problem for students and others.



Fig. 9 Google Map of Shivli and an artistic view of PV panels layout.

## 7. Financial Analysis of IIT Kanpur Solar power plant

Apart from being a research facility, the PV system would also generate power to be used within the IITK system, or be supplied to the grid or be made available to local community. In case the power generated just replaces the consumption

### Economics of Solar power generation

	PV Crystalline	PV - Concentrators	PV – Thin Film	Total
Capacity (kW)	300	100	100	500
Expected Power Generation per year #	443644	184723	147880	776247
Value if consumed by IITK (per year)	443644*3.3 =Rs. 13.31 Lakh	184723*3.3 = Rs. 6.1 Lakh	147880*3.3 = Rs. 4.44 Lakh	Rs. 23.85 Lakh
Value if sold to Grid (per year)@	443644*11.4 Rs. 50.6 Lakh	184723*11.4 Rs. 21.06 Lakh	147880*11.4 = Rs. 16.86 Lakh	Rs. 88.49 Lakh
Value to Rural Community	Value of electricity consumed and improved quality of life			
	Additional Benefits due to CDM Credits			

Note: # - Based on solar calculator at [www.PVwatt.org](http://www.PVwatt.org) for New Delhi (closest available site) with DC to AC Derate Factor of 0.770.

For PV Crystalline: Array Type: Fixed Tilt, Array Tilt: 28.6°, Array Azimuth: 180.0°

PV – Concentrators Array Type: Fixed Tilt, Array Tilt: 28.6°, Array Azimuth: 180.0° (2-axis tracking)

PV – Thin Film: Array Type: Fixed Tilt, Array Tilt: 28.6°, Array Azimuth: 180.0°

Note: @ - Based on “Guidelines for Generation Based Incentive Grid Interactive Solar PV Power Generation Projects” by MNRE guidelines for plant to come after Dec. 2009. Applicable for 10 years for phased-plant size of 1 MWp (with min. initial capacity of 250 kWp). (to be further explore with MNRE/UPERC in terms of applicability of incentives and appropriate regulations) Available at [http://mnre.gov.in/pdf/guidelines\\_spg.pdf](http://mnre.gov.in/pdf/guidelines_spg.pdf)

### **Benefit for Standalone Solar PV Plant:**

In case the plant is proposed as a standalone basis, Central Financial Assistance (CFA) in form of capital subsidy of Rs.150/Wp for systems with battery bank of 6 hrs or, Rs.115/Wp without battery bank (for organizations not availing accelerated depreciation) may be available on case-to-case basis.

So: MNRE notification No. No32/01/2009-10/PVSE available at <http://mnre.gov.in/adm-approvals/spv-aa0910.pdf>

### **Benefits under Clean Development Mechanism**

As per Kyoto Protocol under the United Nations Framework Convention on Climate Change (UNFCCC) carbon offsetting projects in (non-Annex-I) developing countries like India. Solar PV projects that replace electricity consumption from the grid can qualify for taking benefits from sale of carbon credits if certain eligibility criteria are met. The expected emission reductions as CERs can be sold separately under numerous carbon finance schemes available.

Even though the economics of power generation would be established in the long-run, the plant has a number of intangible benefits including push to research and education in the field of Solar Energy. Initial calculations show that significant benefits can be derived if power is sold to the grid. Carbon credits can provide additional benefits part and efforts need to be put in to submit this as a CDM project, if feasible as per CDM regulations. The government (state as well as central) and IREDA can be approached to explore provisions for capital subsidies and financing, if required.

### **8. ENVIRONMENTAL PROTECTION PLAN**

Before implementation of any new technology, we need to look at its impact on environment. In case of Solar PV Technology, we need to worry about impact on environment during production, installation and disposal of PV panels. Since our solar sub-station does not involve production of PV panels, our primary concern is environmental impact during installation and disposal. There is no issue of air or water pollution during installation and operation. We will develop the mechanism of disposal of PV panels after their (15-20 yrs) in the project.

Additional concerns are from energy storage technologies and some mechanisms will be developed for their safe disposal as well.

### **9. PROJECT EXECUTION**

#### ***9.1. Project execution strategy***

##### **I<sup>st</sup> phase (1-3 yrs):**

- Install and commission technology-demonstrator part of Solar Energy Research Enclave (**500kWp**) **solar energy sub-station**.
- At the end of two years, the **solar energy sub-station** will be supplementing power requirement of IITK in the day time.
- Research programs will be initiated in c-Si solar cells, fuel cells and power electronics.

## II<sup>nd</sup> Phase (4-6 yrs):

- Expansion of solar plant capacity to 1 MW with inputs from Ist phase
- Testing of developed technologies to improve efficiency and lower the cost of the systems
- Setting up facilities for basic research and technology development

### 9.2. Project schedule

Objectives	Year 1				Year 2				Year 3			
	Q1	Q2	Q3	Q4	Q1	Q2	Q3	Q4	Q1	Q2	Q3	Q4
<b>Technology Demonstrator</b>												
Procurement of PV modules (200KW)												
Procurement of Fuel Cell (50KW)												
Procurement of electronics												
Procurement of batteries												
Installation & Initial testing period												
Monitoring and Control												

\*\* Site preparation and building is expected to be ready in about 9 months as well. Not included in this project.

## 10. Technology Development

Steady increase in energy demand together with emphasis on its clean and green production has limited technological options. One of the solutions can be provided through solar based technologies. Solar PV and solar thermal technologies are known for decades. Solar based Fuel cells is another important area of current developments. Though, there have been spurt in photovoltaic and solar thermal power plant installations in recent years, cost of electricity generation from these is still quite high. There are number of reasons for this higher cost, some known while others yet to be explored. Hence, there is need to work in different materials, device designs, processing and energy delivery mechanisms to generate efficient and cost effective power. The research and development in different facets of solar based technologies will be a one of the focus in the Is Phase of the present proposal. The technology developed and experience gained in Ist Phase will be utilized for making better, cheaper and efficient devices to be used in actual modules. It can be done through transfer of technology (TOT) mode to some industry or if facilities and support is provided in IInd Phase, it can be done at the Solar Energy Research Enclave. Details of some projects are given in Annexure C.

The goal of the fuel cell research is to deliver 1.0kW solid oxide fuel cell stack and the equivalent fuel generation system to the technology bed, subject to the availability of adequate funding. Particular focus is to develop a system that can be used as an electrolyzer as well as a fuel cell stack. Such system may provide adequate stability of the solar power station, consuming electricity at lean hours and delivering electricity during peak hours. Other objective is the optimized design of the fuel cell so that it can utilize multiple fuels such as, pure hydrogen, reformed hydrocarbon, and liquid fuels. Development of such system requires integration of basic research in several areas including catalysis, thermal management, and material development. Such basic research aiming at the development of compliant technology will be pursued in second-phase of the project.



## Annexure A. CV of core members of SERE team

Santanu K. Mishra

Assistant Professor, Department of Electrical Engineering

Email: [santanum@iitk.ac.in](mailto:santanum@iitk.ac.in) Phone: +91-0512-259-6249

---

### **Education Background:**

2006 Ph.D. in Electrical and Computer Engineering  
University of Florida, Gainesville, FL, USA.

2000 Master of Technology in Electrical Engineering  
Indian Institute of Technology Madras, Chennai, India.

### **Experience:**

2008-Present: Assistant Professor, Department of Electrical Engineering, IIT Kanpur, U.P., India

2004-2008: Senior and Staff Applications Engineer at the International Rectifier IC Design Center, North Kingstown, RI, USA.

### **Current Research Interest:**

- Telecom Power Plant Architecture Design for Rural Application
- Parallel Operation of Non-Interleaved DC/DC Converters
- Large-signal Linearization of Non-linear converters
- Digital Controller Design for Solar charge controllers

### **Active Research Projects:**

1. *Dynamic Modulators for Large-Signal Linearization of Boost Converters*
  - a. Funding Agency: R& D Department, IIT Kanpur
  - b. Duration: September 2008-December 2009
2. *Variable Phase Input Power Plant Design for Telecom Application*
  - a. Funding Agency: Bharat Sanchar Nigam Ltd. (BSNL)
  - b. Duration: December 2008-December 2009

### **List of Publications:**

- [1] K. D. T. Ngo, **Santanu K. Mishra**, and S. Thekkevalappil, "Pulse width modulator with carriers derived from converter waveforms," *IEE Electronics Letters*, Feb 2005.
- [2] K.D.T. Ngo, **Santanu K. Mishra**, and M. Walters, "Synthetic ripple modulator for synchronous buck converter," *IEEE Power Electronics Letters*, Dec. 2005.
- [3] **Santanu K. Mishra**, Steve Zhou, and George Schuellein, "Design of average current mode control with limited DC gain based redundant parallel multiphase VRM," *Proceedings of PCIM Europe*, Nuremberg, May 2006.
- [4] **Santanu K. Mishra**, Steve Zhou, Wenkang Huang, and George Schuellein, "Design of redundant paralleled multiphase VRM system with improved efficiency and dynamic response," *IEEE-Industry Application Society Annual conference*, Sept. 2006.
- [5] Wenkai Wu, Ken Boyden, **Santanu Mishra**, George Schuellein, "Phase Shedding Control Algorithm for Multiphase Voltage Regulator," *PCIM China*, June 2008.
- [6] **Santanu K. Mishra** and Khai D. T. Ngo, "Dynamic Characterization of Synthetic Ripple Modulator in a tightly regulated distributed power application," *IEEE Tran. On Industrial Electronics*, Vol. 56, No. 4, April 2009, pp.1164-1173.

- [7] **Santanu K. Mishra** and Khai Ngo, "Dynamic Response Optimization of the Synthetic Ripple Modulator for a Point-of-Load Converter with Adaptive Voltage Positioning," in *IEEE Proceedings on Compatibility and Power Electronics (CPE)*, Badajoz, Spain, pp. 402-405, May 2009.
- [8] **Santanu K. Mishra**, "Design Oriented Analysis of Modern Active Droop Controlled Power Supplies," in *IEEE Tran. On Ind. Elect.*, vol. 56, Sept. 2009.

## **Raj Ganesh S. Pala**

### **EDUCATION AND TRAINING**

- 1999-2005                      University of Utah, Salt Lake City, UT  
Ph.D., Physical Chemistry
- 1997-1998                      Indian Institute of Science and  
National Center for Biological Sciences, Bangalore, India  
Masters in Science (Computational Biophysics)
- 1992 - 1996                      Central Electro-Chemical Research Institute, Karaikudi, India  
Bachelors in Chemical and Electrochemical Technology

### **RESEARCH AND PROFESSIONAL EXPERIENCE**

- 2008-Present                      Assistant Professor, Chemical Engineering Department  
Indian Institute of Technology, Kanpur, UP 208016 INDIA
- 2005 - 2008                      Post Doctoral Associate, Department of Chemistry and Biochemistry  
University of California, Santa Barbara

### **SELECTED PUBLICATIONS**

1. “CO oxidation by Ti-and Al-doped ZnO: Oxygen activation by adsorption on the dopant”, R. G. S. Pala, W. Tang, M.M. Sushchikh, J.N. Park, A.J. Forman, G.Wu, A.K-Shwarschtein, J. Zhang, E. McFarland and H. Metiu, *J. Catal.* **266**, 50-58 (2009).
2. “Selective promotion of a specific methanol adsorption mode via the cation substitutional doping of the ZnO(10 $\bar{1}$ 0) surface”, R. G S. Pala and H. Metiu, *J. Catal.* **254**, 325-331(2008).
3. “Critical epi-nucleation on reconstructed surfaces and a model study of Si(001) homoepitaxy”, Pala, R.G.S and Liu, F., *Phys. Rev. Lett.* 95 (2005) 136106-136110

### **PRIMARY RESEARCH INTERESTS**

Heterogeneous catalysis, Electrochemical energy conversion and storage.

### **GRADUATE ADVISOR**

Prof. Feng Liu,  
Director, Center for computational design and testing of nanomaterials,  
Department of Materials Science and Engineering,  
University of Utah.

**Malay K. Das**  
Assistant Professor, Department of Mechanical Engineering,  
Indian Institute of Technology Kanpur  
**Telephone No. (with STD code):** 91-0512-2597359 (O)  
**Fax No.:** 91-0512-2590007 (O)  
**E-mail:** mkdas@iitk.ac.in

### EDUCATION

PhD in Mechanical Engineering, *May 2008*  
The Pennsylvania State University, University Park, PA, USA

**PRESENT POSITION**                      Since *June 2008*  
**RESEARCH INTEREST**              Electrochemical systems, high-temperature thermophysics

### CURRENT PROJECTS

1. IIT Kanpur, initiation grant: “Multiscale modeling of Planar Solid Oxide Fuel Cell”: 10.0Lakhs INR  
PI: M. K. Das  
Status: approved
2. Submitted to DST Nanomission: “Synthesis of Anode-Supported Solid Oxide Fuel Cell with Improved Ionic Conductivity via Plasma Spraying,”: 293.18Lakhs INR  
PI: K. Balani, Assistant Professor, MME, IIT kanpur  
Status: Under review
3. Submitted to DST Nanomission: “Development and Performance Evaluation of Carbon Nanocoil Structure for the Catalyst Support in PEM Fuel Cells,”: 56.59Lakhs INR  
PI: K. Kar, Associate Professor, ME, IIT kanpur  
Status: Under review

### RECENT PUBLICATIONS

1. **Das, M. K.**, Chowdhury, A., and Thynell, S. T., “Radiative Pyrolysis of a Double-base Propellant”, To be presented in the AIAA Joint Propulsion Conference, Denver, USA, Aug 2009.
2. **Das, M. K.**, and Thynell, S. T., “Corona, Spark, and Electrothermal\_chemical Plasma Ignition Systems”, Book chapter submitted to Wiely-VCH, Germany for the ‘Handbook of Combustion, Vol 3’, March 2009.
3. **Das, M. K.**, Chowdhury, A., and Thynell, S. T., “Radiative Pyrolysis of JA2 Propellant”, Proceedings of the Combustion Institute, 5<sup>th</sup> Eastern State Combustion Institute Meeting, University of Virginia, Charlottesville, USA, March, 2007.
4. **Das, M.**, and Thynell, S. T., “Two-dimensional Conduction Effect in Estimating Radiative Heat Flux from a Capillary Discharge”, *Journal of Thermophysics and Heat Transfer*, Vol. 20, No. 4, 2006, pp. 903-911.
5. Li, J-Q., Litzinger, T, **Das, M.**, and Thynell, S. T., “Recombination of Electrothermal Plasma and Decomposition of Plasma-Exposed Propellants”, *Journal of Propulsion and Power*, Vol 22, No. 6, 2006, pp. 1353-1361.
6. Li, J-Q., Litzinger, T, **Das, M.**, and Thynell, S. T., “Study of Plasma Propellant Interaction during Normal Impingement”, *Journal of Propulsion and Power*, Vol. 22, No. 5, 2006, pp. 929-937.

## **S Sundar Kumar Iyer**

### **Associate Professor**

: Department of Electrical Engineering  
Indian Institute of Technology Kanpur  
Kanpur – 208 016  
Phone: 0512-259 7820  
Email:sskiyer@iitk.ac.in

#### **Professional Interests:**

- (i) Organic Solar Cells
- (ii) Photovoltaic systems
- (iii) Printable Electronics
- (iv) VLSI Technology, Devices and Circuits

#### **Education Background:**

- o B.Tech -- Indian Institute of Technology Madras, 1990
- o M.S. -- Indian Institute of Technology Madras, 1993
- o Ph.D. -- University of California at Berkeley, 1998

#### **Industry Experience**

- o Staff Engineer and later Advisor Engineer at IBM Microelectronics, Hopewell Junction New York (1998 to 2004)
- o Summer internship at Texas Instruments, Dallas (Summers of 1993 and 1995)

#### **Teaching Experience**

- o Visiting Faculty at IIT Kanpur from July to December, 2003
- o Assistant Professor at IIT Kanpur from July 2004 till date

#### **Projects**

- o “Low cost and flexible solar cells for developing countries”, Swiss National Science Foundation, 1-10-2005 to 31-07-2009
- o “Fabrication of solar cells with biomimetic design of chlorophyll pair present in green leaves”, under REACH, IIT Kanpur, 08-05-2008 to 07-05-2011
- o “Organic Semiconductor Electronics”, MHRD, Govt. of India, 01-04-2005 to 30-09-2008
- o “Pan IIT Solar Energy Initiative”, DST, Govt. of India, Writing Detailed Project Report, 08-2009

#### Select Papers

[1] “A Comparative Study of Poly(3-octylthiophene) and Poly(3-hexylthiophene) Solar Cells Blended with Single Walled Carbon Nanotubes”, Arun Tej Mallajosyula, S. Sundar Kumar Iyer, and Baquer Mazhari, *Japanese Journal of Applied Physics*, volume 48, January, 2009, p. 011503 (6 pages)

[2] “Photovoltaic effect in arylenevinylene-co-pyrrolenevinylene(AVPV)” Ankur Solanki, AshishGupta, S. Sundar Kumar Iyer, AshishGarg, *Solar Energy Materials & Solar Cells*, vol. 93, Issue 14 November, 2008, pp. 211–214.

[3] “Characterization of matrix and isolated organic solar cells”, Arun Tej Mallajosyula, Naveen Srivastava, S. Sundar Kumar Iyer and Baquer Mazhari, *Solar Energy Materials & Solar Cells*, 19 September, 2008, doi:10.1016/j.solmat.2008.09.027 [article in press]

[4] “Photovoltaic effect in single-layer organic solar cell devices fabricated with two new imidazolin-5-one molecules” Vibhor Jain, Basanta Kumar Rajbongshi, Arun Tej Mallajosyula, Gitalee Bhattacharjya, S. Sundar Kumar Iyer, Gurunath Ramanathan, *Solar Energy Materials & Solar Cells*, vol. 92 Issue 9 September, 2008, pp. 1043– 1046

[5] “Degradation Study of Organic Semiconductor Devices Under Electrical and Optical Stresses”, Munish Jassi, R. Gurunath and S. Sundar Kumar Iyer, *IEEE Electron Device Letters*, vol. 29, no.5, May 2008, pp. 442-444.

[6] "Photovoltaic Behaviour of Organic Polymer – PCBM Bulk Hetero Junctions Solar Cells" S. Sundar Kumar Iyer, Dipesh Bajaj and Amruta Bhat, IETE Journal of Research, vol. 52, No. 5, September-October, 2006, pp 391-399

## Monica Katiyar

Professor  
Materials and Metallurgical Engineering Department  
I.I.T. Kanpur  
208016, UP, INDIA  
e-mail: mk@iitk.ac.in  
(0512)-2597941  
web: home.iitk.ac.in/~mk

4093  
I.I.T. Kanpur  
208016  
(0512)-2598520

### **Education:**

Ph.D. Materials Science and Engineering - University of Illinois at Urbana-Champaign, IL  
10-94 Adviser: Prof. John R. Abelson  
M.Eng. Materials Science and Engineering - McMaster University, Ontario  
11-89 Adviser: Prof. Adrian H. Kitai  
B.Tech. Metallurgical Engineering - Indian Institute of Technology, Kanpur, India  
5-87

### **Research and professional experience:**

12/05-present Professor, Materials and Metallurgical Engineering, IIT Kanpur  
9/01-12/05 Associate Professor, Materials and Metallurgical Engineering, IIT Kanpur  
12/97-9/01 Assistant Professor, Materials and Metallurgical Engineering, IIT Kanpur  
10/96-11/97 Device Engineer, RF-1 - Motorola, Inc., Phoenix, Arizona, USA  
8/94-10/96 Process Engineer, COM-1 - Motorola, Inc., Phoenix, Arizona, USA  
7/89-8/94 Research Assistant - University of Illinois at Urbana-Champaign  
9/87-7/89 Research Assistant - McMaster University, Ontario, Canada  
9/87-7/89 Teaching Assistant - McMaster University, Ontario, Canada

### **Publications:**

#### **5 Relevant Publications (microcrystalline silicon, polysilane and device characterization)**

1. Asha Sharma, Monica Katiyar, Deepak, Sanjeev K. Shukla and Shu Seki, *Effect of ambient, excitation intensity and wavelength, and chemical structure on photodegradation in polysilanes*, J. Appl. Phys. , 102(10), 104902 (2007).
2. Asha Sharma, Monica Katiyar, Deepak and Shu Seki, *Polysilane based organic light emitting diodes: simultaneous ultraviolet and visible emission*, J. Appl. Phys., 102(8), 84506 (2007).
3. Asha Sharma, Monica Katiyar, Deepak, S. Seki, and S.Tagawa *Room Temperature Ultra Violet Emission at 357 nm from Polysilane based organic light emitting diodes*, Appl. Phys. Lett. 88, 143511 (2006).
4. Dipti Gupta, M. Katiyar, Deepak, T. Hazra, A. Verma, S.S. Manoharan, A. Biswas *Energy transfer and study of a new iridium based cyclometalated phosphorescent complex*, Optical Materials, 28(12), 1355-1361 (2006).
5. Monica Katiyar and John R. Abelson, *Investigation of hydrogen plasma induced phase transition from a-Si:H to  $\mu$ c-Si:H using real time infrared spectroscopy*, Mat. Sci & Eng. A 304-306 (0), 349-352 (2001).

**Dr. Anoop Singh**  
**Associate Prof,**  
**Dept. of Industrial and Management Engineering,**  
**IIT Kanpur**  
**E-mail: anoops@iitk.ac.in**

His areas of interest include infrastructure regulation, policy and finance, power market reform and regulation, energy efficiency, renewable energy, energy and environment, project financing, energy economics and cross-border energy cooperation. He has been awarded a number of fellowships / scholarships including a Visiting Researcher Fellowship from Asian Development Bank Institute (ADB), Tokyo, a Ph.D. fellowship by United Nations University/Institute for Advanced Studies (UNU/IAS), Tokyo and a research scholarship from Duestcher Akademischer Austauschdienst (DAAD), German Academic Exchange Council), Germany.

He has undertaken a number of research/consultancy projects related to electricity / energy sector for a number of institutions including the World Bank, the UNCTAD, UNU/IAS, AIT, the University of Cambridge, and the Planning Commission. He has also contributed a number of regulatory and policy submissions with reference to formulation of regulations and policies. He has a number of conference, discussion and journal papers to his credit. He is also the Guest Editor to the International Journal of Energy Sector Management (special issue related to India and China). He is a Senior Member of IEEE, a member of International Association for Energy Economics (IAEE) and Life Member of Indian Economic Association (IEA).

He was a Member of the Working Group on Power for the 11th Five-Year Plan, Planning Commission, Government of India. He was also a member of the Core Group on Next Generation Networks (Licensing Issues), Telecom Regulatory Authority of India (TRAI) and Member, Electricity Contract Advisory Board of Multi Commodity Exchange of India (MCX), Mumbai.

#### **RESEARCH ACTIVITIES IN RENEWABLE ENERGY**

- “Informal Markets for Electricity: Economics of lighting for Hawkers in India”, Forthcoming in *International Journal of Energy Sector Management: Special Issue on India* journal
- “A Market for Renewable Energy Credits in the Indian Power Sector”, *Renewable and Sustainable Energy Review* journal, Elsevier, 2009.
- “Rural Electrification in India: Economic and Institutional aspects of Renewables”, with James Cust and Karsten Neuhoff, EPRG WP 0730, University of Cambridge, UK.
- Ongoing research on institutional and implementation issues in Solar PV project in India.

#### **RESEARCH PROJECT**

Title: “The Institutional Framework for Rural Energy Service from Renewables” (2006-07)  
Agency: Dept. of Economics, University of Cambridge, Cambridge (UK)



## Dr RS Anand, IIT, Kanpur

1. Name in Full: Dr .Raghubir Singh Anand
2. Address : EE, IIT, Kanpur  
Phone 2597102(O),2598772(R) Fax No.2590063 Department  
e-mail: [rsanand@iitk.ac.in](mailto:rsanand@iitk.ac.in) , [home.itk.ac.in~rsanand](http://home.itk.ac.in/~rsanand)
3. Present position: Principal Research Engineer
4. Area of Specialization: Microelectronics
5. Current Areas of Research: a) Silicon Technology  
b) Organic/Polymer Semiconductors
6. Academic Qualification



Degree (subjects)	Institution	Year	Marks & Division
M.Tech.	IIT, Kanpur	1991	7.38/10
Ph.D.	IIT, Kanpur	2001	8.1/10

### 7. **Projects, Completed/Ongoing**

- i. Technology Development of Silicon PIN, APD and Quadrant Photodiodes for 1.06  $\mu\text{m}$  Laser Radiation – Phase I and Phase II 1993-2000. 40 Lakhs, Successfully completed.
- ii. Technology Development of Transparent Cathode, 26 Lakhs. , Successfully completed
- iii. Evaluation of Organo-Fullerene Based Material for Photo-sensing, Photo-voltaic & Electro-luminescence Properties, 2004-06, 9.775 Lakhs., Successfully completed
- iv. Study of Efficiency of Polymer Photo-Voltaic Cells & Photo-Detectors using Different Dopants, , 2007-2010, 67 Lakhs.
- v. Evaluation of Organo-Chalcogenolate (S,Se, Te) Metal Complexes and Nanoparticles for Photo-sensing, Photo-voltaic,and Electro-luminescence properties, 2007-2010. 9.9 Lakhs.
- vi. Study of the effect of electro-phosphorescent materials and device structure on the increase of efficiency of organic light emitting diodes, 2009-2012, 28.89 Lakhs

8. **Publication:** Details given at home page [home.itk.ac.in~rsanand](http://home.itk.ac.in/~rsanand)

### 9. **Patents**

1. Santosh Tripathi, Mohammed Nasim, KU Bhasker Rao and **RS Anand**;  
Synthesis of novel asymmetric quinolinoate zinc (II) acetate complex  
(Indian Patent File No.727/DEL/2009)
2. Goel, A., Chaurasia, S., Kumar, V., Manoharan, S., **Anand, R. S**:  
Novel donor-acceptor fluorene scaffolds: A process and uses thereof.  
(Indian Patent File No. 0838DEL2008 dated 28/03/2008).
3. **RS Anand**, A. Giri & Ramesh Prasad, Technology of Polymer and Organic  
Low information content displays.  
(Indian Patent File No. 1525/DEL/2006).

### 10. **Holding of Seminar/Conferences**

and A National Conference on the Emerging Trends in the Photovoltaic Energy Generation Utilization (NCETPEGU) was successfully organized at IIT, Kanpur from 27-29 March, 2008.

<http://www.iitk.ac.in/photovoltaics/>

## Annexure B. Solar Cycle Analysis

Elevation 128 m from sea level

The following data has been collected from NASA site.

<b>Monthly Averaged Insolation Incident On A Horizontal Surface (kWh/m<sup>2</sup>/day)</b>													
Lat 26.417 Lon 80.367	Jan	Feb	Mar	Apr	May	Jun	Jul	Aug	Sep	Oct	Nov	Dec	
22-year Average	3.72	4.67	5.75	6.32	6.57	5.91	4.80	4.48	4.51	4.87	4.26	3.60	

*Parameters for Sizing and Pointing of Solar Panels and for Solar Thermal Applications:*

<b>Monthly Averaged Insolation Clearness Index (0 to 1.0)</b>														
Lat 26.417 Lon 80.367	Jan	Feb	Mar	Apr	May	Jun	Jul	Aug	Sep	Oct	Nov	Dec	Annual Average	
22-year Average K	0.57	0.60	0.62	0.60	0.59	0.52	0.43	0.42	0.47	0.59	0.62	0.58	0.55	
Minimum K	0.44	0.54	0.54	0.57	0.55	0.47	0.34	0.30	0.35	0.46	0.52	0.42	0.46	
Maximum K	0.62	0.68	0.69	0.65	0.61	0.58	0.52	0.49	0.57	0.66	0.67	0.64	0.62	

*Solar Geometry:*

<b>Monthly Averaged Solar Noon (GMT time)</b>													
Lat 26.417 Lon 80.367	Jan	Feb	Mar	Apr	May	Jun	Jul	Aug	Sep	Oct	Nov	Dec	
Average	0649	0653	0648	0639	0635	0639	0645	0643	0634	0625	0623	0632	

*Parameters for Tilted Solar Panels:*

<b>Monthly Averaged Radiation Incident On An Equator-Pointed Tilted Surface (kWh/m<sup>2</sup>/day)</b>														
Lat 26.417 Lon 80.367	Jan	Feb	Mar	Apr	May	Jun	Jul	Aug	Sep	Oct	Nov	Dec	Annual Average	
SSE HRZ	3.72	4.67	5.75	6.32	6.57	5.91	4.80	4.48	4.51	4.87	4.26	3.60	4.95	
K	0.57	0.60	0.62	0.60	0.59	0.52	0.43	0.42	0.47	0.59	0.62	0.58	0.55	

Diffuse	1.12	1.29	1.54	1.91	2.16	2.44	2.48	2.31	2.00	1.41	1.04	1.00	1.73
Direct	5.34	6.11	6.77	6.56	6.38	5.01	3.35	3.17	3.90	5.99	6.39	5.55	5.37
Tilt 0	3.62	4.63	5.68	6.19	6.54	5.88	4.78	4.45	4.45	4.83	4.14	3.52	4.89
Tilt 11	4.18	5.18	6.06	6.31	6.44	5.73	4.70	4.45	4.60	5.30	4.78	4.14	5.15
Tilt 26	4.75	5.68	6.28	6.18	6.02	5.30	4.41	4.29	4.62	5.69	5.41	4.78	5.28
Tilt 41	5.05	5.86	6.17	5.74	5.31	4.63	3.94	3.94	4.42	5.77	5.74	5.16	5.14
Tilt 90	4.10	4.30	3.70	2.63	2.05	1.87	1.82	1.95	2.51	3.98	4.56	4.34	3.15
OPT	5.10	5.86	6.29	6.31	6.54	5.88	4.78	4.47	4.64	5.78	5.78	5.25	5.55
OPT ANG	50.0	42.0	29.0	13.0	0.00	0.00	0.00	6.00	20.0	38.0	49.0	53.0	24.9

**Parameters for Sizing Battery or other Energy-storage Systems:**

<b>Minimum Available Insolation Over A Consecutive-day Period (%)</b>													
Lat 26.417 Lon 80.367	Jan	Feb	Mar	Apr	May	Jun	Jul	Aug	Sep	Oct	Nov	Dec	
Min/1 day	16.1	3.64	25.9	14.3	28.9	16.4	5.62	11.6	4.20	14.9	13.3	8.05	
Min/3 day	38.2	43.5	49.1	59.9	61.6	41.2	38.6	27.0	30.5	35.8	47.5	29.6	
Min/7 day	51.1	61.1	69.0	76.2	83.0	60.5	54.7	48.1	49.0	42.5	52.3	48.8	
Min/14 day	61.8	78.0	80.8	86.1	89.4	76.7	69.6	64.0	63.8	62.2	63.5	62.0	
Min/21 day	65.4	86.0	80.7	91.5	92.0	85.5	73.6	65.9	71.9	77.7	74.3	65.7	
Min/Month	77.9	89.7	88.0	93.9	92.8	90.3	79.5	72.0	75.8	78.8	83.3	73.0	

**Parameters for Sizing Surplus-product Storage Systems:**

<b>Available Surplus Insolation Over A Consecutive-day Period (%)</b>													
Lat 26.417 Lon 80.367	Jan	Feb	Mar	Apr	May	Jun	Jul	Aug	Sep	Oct	Nov	Dec	
Max/1 day	142	133	131	128	120	134	160	165	162	135	131	125	
Max/3 day	138	128	130	121	115	127	152	157	158	134	128	124	
Max/7 day	132	126	124	118	112	126	145	140	149	126	123	120	
Max/14 day	125	121	118	112	109	121	134	123	142	122	115	116	
Max/21 day	118	118	114	109	107	117	126	119	128	120	110	114	
Max/Month	110	114	112	108	104	112	122	116	123	112	108	109	

**Cloud Information:**

Monthly Averaged Daylight Cloud Amount (%)													
Lat 26.417 Lon 80.367	Jan	Feb	Mar	Apr	May	Jun	Jul	Aug	Sep	Oct	Nov	Dec	Annual Average
22-year Average	32.5	28.1	27.1	28.8	37.6	57.2	80.1	75.9	56.7	23.7	14.1	25.1	40.7

Monthly Averaged Top-of-atmosphere Insolation (kWh/m <sup>2</sup> /day)													
Lat 26.417 Lon 80.367	Jan	Feb	Mar	Apr	May	Jun	Jul	Aug	Sep	Oct	Nov	Dec	Annual Average
22-year Average	6.52	7.74	9.21	10.4	11.0	11.3	11.1	10.5	9.57	8.18	6.82	6.12	9.06

Comparison of some parameter with large scale solar power plants

Place	Lat	Long	Capacity	Monthly Averaged Insolation Incident On A Horizontal Surface (kWh/m <sup>2</sup> /day) min	Monthly Averaged Insolation Incident On A Horizontal Surface (kWh/m <sup>2</sup> /day) max	Annual Averaged Insolation Clearness Index min	Annual Averaged Insolation Clearness Index max
Beneixama, Alicante, Spain	38.5	0.5	20 MW	2.65	7.75	0.53	0.68
Deming, New Mexico, USA	32.5	107.5	300 MW	2.41	4.7	0.31	0.49
The Solana solar plant, 70 m	32.867	112.717	280MW	2.72	4.94	0.34	0.53
Jumilla, Murcia, Spain	37.983	1.117	20MW	2.33	7.72	0.55	0.68
Mildura, Victoria, Australia	34.217	142.067	154 MW	1.99	6.1	0.36	0.53
IIT Kanpur	26.5	80.5	500 MW	3.6	6.32	0.46	0.62

Clearly Kanpur has better climatic conditions for solar power than most of the other power plants. Also it may be noticed that Kanpur has better minimum clarity and highest minimum solar insolation. This might have a bearing on the design of the PV power plant.

## **Annexure C. Research projects**

### ***Development of High Efficiency Silicon and Polymer Solar Cells***

PI: Dr. R. S. Anand

Crystalline and poly-silicon technologies are the leading technologies in producing photovoltaic cells and modules. More than 90% solar panels used now are manufactured using silicon. Theoretical efficiency up to 29% is achievable. Highest efficiency of about 22% has been achieved at commercial levels by the best of companies like Sanyo and Sun Power. Most of the Indian companies produce silicon solar cells at about 15-16% efficiency. A 0.5% increase in efficiency of solar cells will lead to large saving in basic solar cell and module cost. Apart from increasing the efficiency of the basic cells, other important aspects is to find alternate material for cell manufacturing and also to decrease the usage of silicon by using thinner wafer and thin films of few microns. Under the project, cost of the basic solar cell will be reduced by increasing the efficiency of the basic solar cell and using thinner wafers.

Polymer solar cell comes under the third generation of solar cells. It is not based on conventional p-n junction. Hybrid polymer solar cells have demonstrated the way out to higher efficiency. It has the potential of fabrication on large glass, flexi and other low cost substrates. As an alternative to silicon technology, polymer solar cells can provide cheap electricity provided its efficiency and lifetime are further increased.

We have developed state of the art polymer solar cells on small 50x50 mm<sup>2</sup> glass substrates under a sponsored project. About 4% efficiency has been achieved on glass substrate. This is the highest efficiency polymer solar cells demonstrated in the country. We have made small polymer solar modules capable of driving small electronic gadgets like watch, calculator and driving LEDs. Further support is needed to develop these devices on large and thin substrates with higher efficiency, stability and lifetime.

#### **1.1.1 Silicon Solar Cells-**

To date, 19% efficiency mc-silicon and 23% single crystal silicon solar cells have been developed by the world top companies like Sun Power and Sanyo.

In the 1st phase, silicon solar cells of 17% and 20% efficiency in multi-crystalline (mc) and single crystal solar cells respectively will be developed. The developed cells will be translated into modules at one of the module manufacturing unit. We have been working in silicon devices for long time. We have developed specialized large area silicon PIN detectors under sponsored projects and also high voltage inter-digitated bipolar transistor. We have hand on

experience in etching, doping, oxidation, nitridation, inter-digited contact formation, gettering to increase the lifetime, defect free wafer polishing, die bonding working at our Lab. We are doing characterization of small area polymer solar cell on routine basis. The increase in minority carrier lifetime, reduced surface recombination velocity due to better passivation, inter-digited back contact for increasing the front exposed area and decrease in wafer thickness will lead to substantial improvement in efficiency and reduction in silicon solar cell cost. The following two methods will be used to achieve the target.

- (i) Passivated Emitter solar cell process will be developed to achieve 17% efficiency in mc-silicon.
- (ii) Back Inter-digited/point contact technology will be developed for 20% efficiency single crystal solar cells.

### 1.1.2 Polymer Solar Cells:

The state of art is 5.4% single layer hybrid solar cells of P3HT:PCBM from Plexcore and more than 6.5% efficiency using tandem solar cells from Prof AJ Heegar group from Santa Barbara University.

Polymer solar cells of 5-6 % efficiency with better stability and lifetime will be developed. Module capable of charging cell phones and Laptop battery will also be developed. The route of achieving higher efficiency depends on quality of material, processing and device structure. About 4% efficiency has already been achieved under DRDO sponsored project. Enough experiments have been done during the course of implementation of the present sponsored project that higher efficiency of 5-6% and more is possible.

### 1.1.3 Equipments

#### a) Silicon Solar Cells

The present industry state of art is using 6” wafers. To develop high efficiency silicon solar using thin wafers require industry manufacturing setup, a whole lot of new equipments like wet station for cleaning, etching, rinsing, dopant deposition station, heating chamber/furnace for dopant drive-in, oxide, nitride deposition for passivation, front and back contact, consumable materials, automation tool, characterization tools and manpower will be required. A sketch of 30MW manufacturing line is given below. The cost of it may run into few tens of crores.

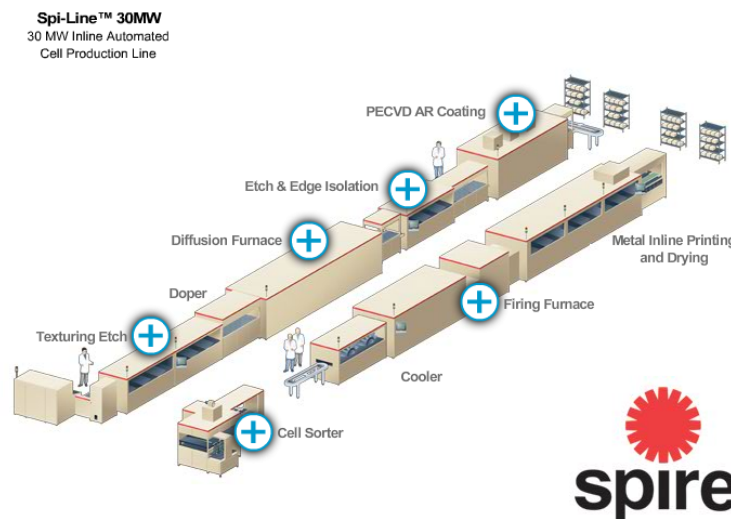

However, at R&D level if technology of high efficiency solar is to be developed at demonstrative prototype level, the scale and cost of equipments can be reduced. The developed processes and technology can be transferred to some industry for manufacturing. A list of basic equipments and tools required for R&D in silicon solar cells is given below.

<u>Sr No.</u>	<u>Process</u>	<u>Equipment</u>	<u>Approximate Cost</u>
(i)	Etching and texturing station 2 Nos With Fume Hoods	Custom made	Rs.10,00,000
(ii)	DI Water facility DI Water System	Millipore/Nanopore	Rs.10,00,000
(iii)	P <sup>+</sup> deposition through doped oxide and drive in ) ) )		
(iv)	N <sup>+</sup> Dopant Deposition )	Four Stack or 2	Rs.500,00,000
a.	Drying and )	Two Stack Furnaces	
b.	Dopant drive in furnace )	with accessories	
(v)	Oxidation for Passivation )		
(vi)	Nitridation	PECVD	Rs.200,00,000
(vii)	Front/Back contact Patterning	Mask aligner	Rs.100,00,000
(viii)	Edge Isolation/grooving LASER with Control	Nd-YAG based	Rs. 50,00,000
(ix)	Metal deposition and Sputtering System.	High Vacuum	Rs.100,00,000
(x)	Screen Printing Equip. with Control	Automated	Rs. 50,00,000
(xi)	High Purity Metal, dopants, Sputtering targets, Al/Ag Pastes, Gases, Raw Wafers (c/mc-silicon) Chemicals, Gas Handling System	Consumables	Rs.100,00,000
(xii)	Characterization Equipments, (a) IV characterization, (b) Solar Simulation,		Rs.30,00,000 Rs.30,00,000



(c) Wafer/Semiconductor Lifetime Measurement System,	Rs20,00,000
(d) Spectral Response System	Rs.20,00,000
(e) Film Thickness Measurement	Rs.30,00,000
(f) Spreading Resistance for Junction Depth	Rs.30,00,000
(xiii) Salary (5 Project Scientists/Engineers @Rs.20000/month, 5 Project Associates @10000/month)	Rs.54,00,000
(xiv) Travel	Rs.10,00,000
<b>Total</b>	<b>Rs.13,94,00,000</b>

#### b) Polymer Solar Cells

Under a DRDO sponsored project, 4-5% efficiency solar cells and small PV modules enough to drive small electronic gadgets have been developed. Shelf Life of about 1 year has been obtained after extensive experiments and measurements. To make the technology viable for commercial application, further work to improve efficiency, lifetime and experiment with different materials and develop other film deposition techniques like spray/dip coating etc. are required. To do this, some improvement in existing facilities is desired. Also, support for buying the consumable and high purity material is needed.

(i) Custom Made Spray Deposition/ Dip Coating System	Rs.50,00,000
(ii) Improvement in Existing Evaporation/ Sputtering System	Rs.50,00,000
(iii) Chemicals and High Purity Materials	Rs.50,00,000
(iv) Travel and Contingency	Rs.10,00,000
(v) Salary (1 Project Scientist @Rs.20000/m and Project associate @Rs.10000/m)	Rs. 9,80,000
<b>Total</b>	<b>Rs1,69,80,000</b>

#### 4.1.4 Deliverables

##### a. **Silicon Solar Cells**

Prototype 1000 solar cells generating few KWp power will be developed and technology will be transferred to industry.

##### b. **Polymer Solar Cells**

100 Prototype of Polymer solar cells of about 5% efficiency and polymer solar modules capable of charging battery of cell phone and Laptop will be developed.

### 1.1.4 Budget

In due consideration of the limited budget available under Research and Development head of IITK PV initiative, it is requested that an amount of Rs.62.2 Lacs may please be sanctioned for carrying out the research and development work in silicon and polymer solar cells. Details are given below. Further support for facilities as listed under head - 5. Equipments above, will be sought from other programs under different initiative.

	Item	BUDGET			(in Rupees)
		1st Year	2nd Year	3rd Year	Total
A.	Recurring				
	1.Salaries/wages(Project Engineer/Scientist)	2,40,000	2,40,000	2,40,000	<b>7,20,000</b>
	2. Consumables	6,00,000	6,00,000	6,00,000	<b>12,00,000</b>
	3. Travel	50,000	50,000	50,000	<b>1,50,000</b>
	4. Other costs (Contingency)	50,000	50,000	50,000	<b>1,50,000</b>
B.	Equipments (Accessories for existing Coating/Evaporation Systems)	40,00,000	-	-	<b>40,00,000</b>
C.	Subtotal (A+B)	49,40,000	9,40,000	9,40,000	<b>62,20,000</b>
D.	Overheads (20% of the subtotal)	Nil	Nil	Nil	<b>Nil</b>
	Grand Total (C+D)	<b>49,40,000</b>	<b>9,40,000</b>	<b>9,40,000</b>	<b>62,20,000</b>
	Total FEC* (USD)	US\$32,000			<b>US\$32,000</b>

## ***Solid state reduction route for the preparation of low cost electronic grade Si in solar cell application***

P.I. : Dr. K. Mondal

### **Project summary:**

Increasing energy requirement in modern era, excessive consumption of limited fossil fuel and ever-increasing environmental pollution demand alternative energy sources which are also clean and green. Solar energy is one such energy sources available in plenty in nature and photo-voltaic (PV) industry is growing at a fast rate. Electronic grade silicon is one of the major requirements in making high efficiency solar cell. However, very high cost associated with the making of solar cell is one of the major challenges in PV industry. Cost of production of electronic grade silicon is one of the factors that add to the total cost of the solar cell. The main objective of this project is to find out alternate route for the production of electronic grade silicon.

### **Main objective:**

Investigation on the alternate solid state production route for making electronic grade silicon

### **Origin of the proposal:**

The most common and popular method for the preparation of electronic grade Si is by pyrometallurgical route where  $\text{SiO}_2$  is reduced by coal/coke/wood chips at high temperature and then purification of reduced Si through successive stages of mineral beneficiation and chemical reaction (RUSKA method). However, the present method would try to reduce Si from low purity  $\text{SiO}_2$  in a solid state reduction route by using aluminium or carbon as reductant. High energy mechanical alloying/milling will be used to facilitate solid state reduction of  $\text{SiO}_2$  at an accelerated rate at much lower temperature (300-400C) (reaction milling). Suitable method will be used to separate and purify Si. Possible cost reduction can be possible since this process will take place at much lower temperature than the existing method.

**BUDGET ESTIMATES: SUMMARY**

(in Rupees)

	Item	BUDGET		Total
		1 <sup>st</sup> year	2 <sup>nd</sup> year	
A	Recurring			
	Consumables (WC balls and hardened steel balls 200 nos each; Chemicals)	1.5 lakh	1.5 lakh	3.0 lakh
	Contingency	0.3 lakh	0.3 lakh	0.6 lakh
B	Equipment (*2 nos 250ml WC vial + 2 nos 250 ml hardened steel vial ball milling)	5.5 lakh	-	5.5 lakh
	Glove box	6.0 lakh	-	6.0 lakh
	Total	13.3 lakh	1.8 lakh	15.1 lakh
C	Institute Overhead (20%)			3.02 lakh
	Grand Total (A+B+C) Total FEC*			18.12 lakh

\*FEC - Foreign Exchange Component

Foreign Exchange component in (Euro) equivalent of rupee amount at the prevailing rates may be furnished.

**Justification for consumables and equipment:**

The method will be using high energy planetary ball mill. Currently, there is a ball mill with two vials with controlled atmosphere attachments (Fritsch P5). There is a provision to use four vials at a time. Separate vials will be used only for this project in order to avoid contamination. Hence, four vials (two WC vial and 2 hardened steel vials) will be purchased. High and moderate purity powders (oxide and elemental) and chemicals will be purchased for the reduction purpose. Glove box will be used to protect the reduced powder from further oxidation since all the loading and unloading of powder will be performed in the glove box.

## ***Energy storage technologies***

The successful utilization of renewable energy in the Indian context is critically dependent on energy storage technologies. In the Indian context, greatest impact of solar energy will be felt if we can utilize solar energy to power areas (typically villages and small towns) which are not connected to the grid or in areas where the grid is not functional for greater part of the day (and night). In the former case of islanded solar grid, energy storage back up facilities are needed for supplying energy in the night (especially since, the power requirement of villages/small towns are mainly during night time) and in the later case where the solar farm is connected to a grid that is non functional for most part of the day, it is useful to capture and store solar energy and distribute the energy when the grid becomes operational.

Our visits to some typical installations of solar photovoltaic technologies have deepened our conviction on the critical need for strong energy storage development technologies in the context of solar energy. In one of the grid connected solar farm installation, the pv-farm did not have any energy storage facility and the grid became operational predominantly at night. In this instance, all the solar energy that is captured in the day time is wasted due to lack of energy storage facility, and of course no solar capture occurs during night time, and hence, making the whole solar farm more or less non-functional.

While the need for energy storage facilities is clear, many problems have to be addressed before a large scale energy storage facility becomes a reality. The research and technology development thrust for energy storage are towards addressing problems like development of reliable storage devices whose lifetime is as high as a typical solar pv-device (~ 20 years), very less maintenance, need for devices with minimal foot print at a reasonable cost. Currently, the cost of energy storage facility is as high as a solar pv facility, lifetime is lesser than pv-cell and the storage devices requiring considerable area and maintenance.

The areas that are presented here are chosen based on variety of factors like open challenges in research and development, our research strengths and immediate future interests and consequences of potential break through. The different research areas are schematically listed below:

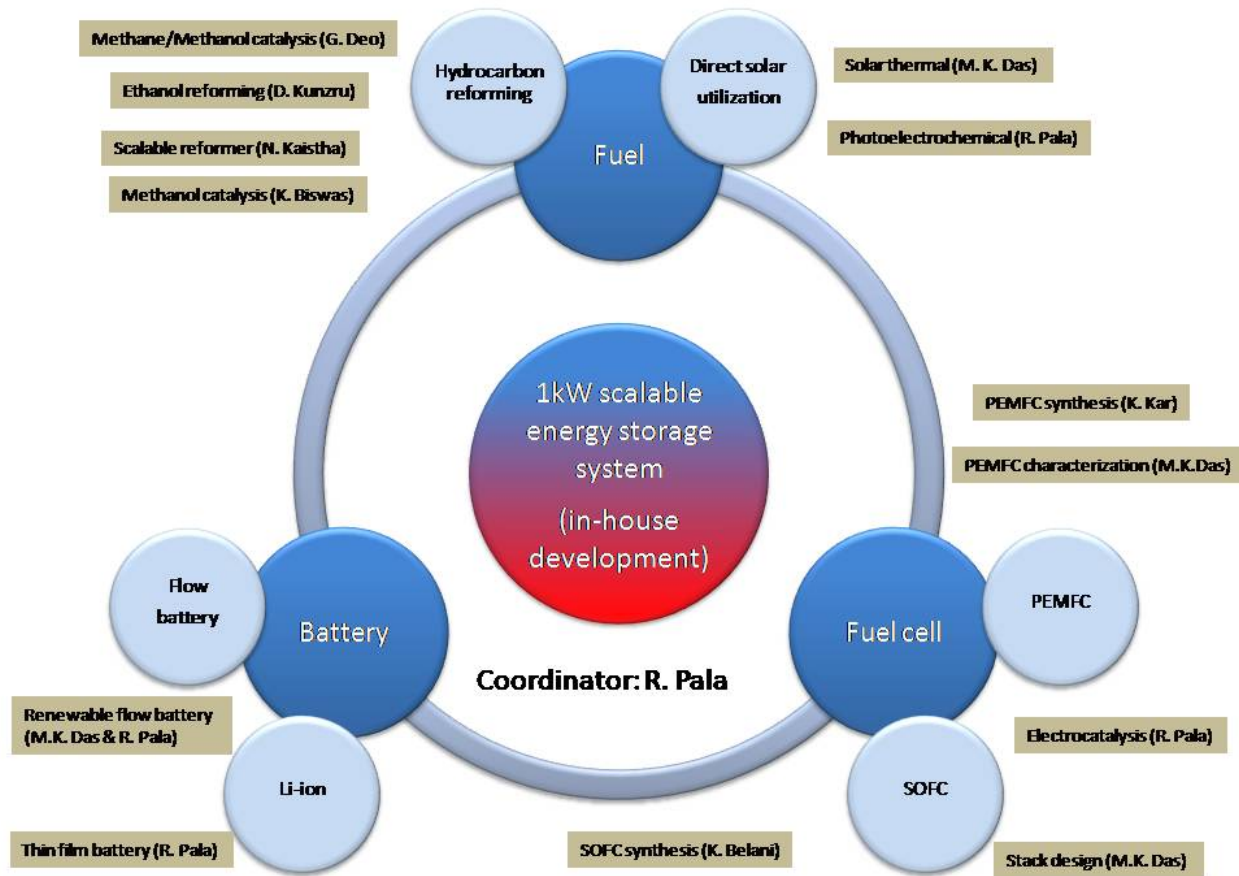

The research proposal on energy storage are broadly divided into three areas. Current proposals covers areas in which we have already started work and does not cover areas which are in early stages of initiation.

## C.1 Fuel Cells

### a) Fabrication of a Solid Oxide Fuel Cell (K. Balani, R. G. Pala, M. K. Das)

A typical Solid Oxide Fuel Cell (SOFC) comprises of ceramic cell components and operates at temperatures of  $\sim 800-1000^{\circ}\text{C}$ . The high-temperature provides opportunities of internal hydrocarbon reforming, eliminates the requirement of expensive noble metal catalysts, promises a fuel-flexible cell design and shows desirable long term stability (5 to 20 years). Due to the above features, the SOFC is envisaged as the future of large-scale stationary power generation.

The first step is a successful development of developing a single anode supported SOFC cell. We will first deposit Yttria Stabilized Zirconia (YSZ) electrolyte using air plasma spray (APS) deposition. Other components like  $\text{CeO}_2$  will be incorporated in the YSZ matrix to enhance ionic conductivity of electrolyte in the intermediate working temperature range of  $350-600^{\circ}\text{C}$ . After successful selection of the electrolyte and optimized conditions, next step will

involve layered deposition of anode supported Lanthanum Strontium Manganate (LSM), followed by YSZ-CeO<sub>2</sub> as the electrolyte, and YSZ-NiO as the cathode to form a working solid oxide fuel cell (SOFC). Mechanical- and microstructural- characterization will be initiated to select and short list the performance versus endurance property of the electrolyte and SOFC as a whole.

Budget: 15 lakhs for impedance spectroscopy, 80 lakhs for fuel cell test station.

**b) Solid oxide fuel cell (SOFC) stack Design (M. K. Das, A. K. Saha)**

Thermal stress is the primary reason for SOFC degradation and failure. The key to an SOFC stack design is to minimize the thermal gradient and to limit the maximum temperature, using only the fuel and oxidizer as the cooling media. Careful design of the fuel and the oxidizer paths are, therefore, central to the stack design procedure. Additional considerations include the pumping power requirement for the cell cooling, and the loss of the active surface area at the electrode-electrolyte interface. Optimization of such wide variety of competing factors requires iterative design, testing, numerical simulations as well as the supporting research on the materials development and synthesis.

Deliverables:

- a. Numerical model of SOFC for single cell as well as stack
- b. Experimental validation of the numerical results (subject to the SOFC synthesis by other research group)

Budget:

Potentiostat: 15lakhs, Furnace: 10lakhs Accessories for temperature measurement: 10lakhs

**c) Fuel generation, reforming and electrocatalysts (R. G. Pala, G. Deo, D. Kunzru, N. Kaistha, K. Biswas)**

For the success of any fuel cell technology, an optimal fuel that can be fed into the fuel cell is critical. Such a fuel needs to be easy to generate and handle, provide optimal fuel cell characteristics without being too expensive. The single SOFC and the stack that are developed will be first run using H<sub>2</sub> as fuel at the anode. H<sub>2</sub> will be produced at a reformer that is integrated with the SOFC. The reformer produces H<sub>2</sub> from hydrocarbons using steam reforming or partial oxidation or by auto thermal reforming. Each of these processes involves different catalytic chemistry and all of the three methods will be investigated. As these processes have existed and optimized in the chemical industry for a large scale (and steady) generation of H<sub>2</sub>, our goal will be to investigate the suitability of these three methods for (comparatively small scale and often unsteady) H<sub>2</sub> generation and integration in a SOFC unit. The main hydrocarbon source that will be investigated in the first year will be methane (as this can be obtained from natural gas), and in the second year other fuels like methanol and ethanol (some of which can be produced from renewable sources) will be investigated.

Even with the most efficient external reforming processes, it is estimated that 20% to 30% of the fuel value of the hydrocarbons is lost during the reforming process. Further, the H<sub>2</sub> produced is hard to store and has to be supplied to the SOFC as and when it is generated. One of the main



advantages of SOFC is that it is possible to reform a variety of fuels at the anode, thereby eliminating a separately integrated reformer along with the SOFC. In-situ reforming of fuels greatly improves the efficiency of the overall processes. At present efforts are underway to reform different fuels like ethanol, methane, methanol, butane, liquefied petroleum gas and diesel at SOFC anode. Traditionally, Ni-based cermets have been used as anode material (as Ni is the one of the best steam reforming catalyst), but Ni also promotes coke formation. We will investigate Cu based cermets and bimetallic alloys based cermets that have effective electronic occupancy as that of Ni to investigate whether coke formation can be reduced. The use of oxygen containing fuels like alcohols will also be investigated to burn the coke that is formed from the hydrocarbon. Further, these electrode materials will be tested for sulphur tolerance, as sulphur present in the hydrocarbons can severely affect the performance of the fuel cell electrocatalysts.

**Budget:** Thermal characterization & calorimetry setup, Multireaction set up, XPS, Raman/IR/UV multispectroscopy set up (2 crores)

#### BUDGET FOR EQUIPMENT

Sl. No.	Generic name of the Equipment along with make & model	Imported/Indigenous	Estimated Costs
1	Impedance spectroscopy		15,00,000
2.	Fuel cell test station		80,00,000
3	Furnace		25,00,000
4	Potentiostat		15,00,000
5	Thermal characterization & Calorimetry		20,00,000
6	Raman/IR/UV multispectroscopy set up		40,00,000
7	XPS		80,00,000
8	Chemisorption characterization		20,00,000

## ***Solar Energy: Economics and Project Implementation***

While choosing specific technical options to meet specific energy needs, economic analysis supplemented with policy support helps to compare the utility of solar and other renewable technologies vis a vis available options. There is increasing relevance of economic aspects in research and technology development as it helps guide development of affordable solutions for wider applications. Economics, project design and implementation experience also provide useful inputs for design of devices and to set technology trajectory for future research.

The existing experience shows that in spite of available technology options, the success of solar energy programs, especially in rural and remote area remains a challenge. The programme design and its implementation need specific attention.

In the above context, we identify the following areas of research

- Solar energy economics, policy and regulation
- Institutional and financial innovations for applications of solar energy including Building Integrated Photo-voltaic (BIPV), hawker lighting etc.
- Implementation Issues for Solar Energy Projects
- Rural Electrification and Solar Energy
- Technology Diffusion
- Clean Development Mechanism (CDM)
- Database for performance evaluation of solar projects
- Design innovations for PV modules and appliances

### **Interested Departments**

- IME
- HSS
- Design Programme

### **Research Support**

Research components of SERE can include project activities on the areas identified above. The SERE could support research initiatives to examine performance of existing projects and its relationship with socio-economic characteristics of the society. Some of the specific projects can deal with development of specific solutions and implementation of solar PV based solutions for rural and urban areas. SERE can also explore development of project templates for solar projects with CDM component including programmatic CDM. SERE could support at least one M.Des. student every year for thesis work on design innovations for solar applications. Similarly, SERE could also provide a platform for supporting M Tech. and Ph.D. research and MBA projects related to solar energy.

To support student research, at particularly at M Tech. and Ph.D. level, SERE may provide additional monthly stipend (may be Rs. 2-5000 for M Tech. and Rs. 3-8000 for Ph.D). Funding for the above research programs and promotion of education and research in solar

energy can be supported with specific funding from associated research initiatives in the country including the Solar Energy Mission.